

Serafim

Serafim S3

CONTENTS

What's in the box?	2
Attach Serafim S3 to a phone	3
Detach Serafim S3 from a phone	4
Controller buttons and ports	5
Disclaimer	6
Warranty	6
Introduction of Serafim Console App	7
PC and Tablet Connection Instructions	18
Technical Specifications	18
Frequently asked questions	18
Safety Notes	20
Product Registration	20
Compliance Information	21

What's in the box?

A

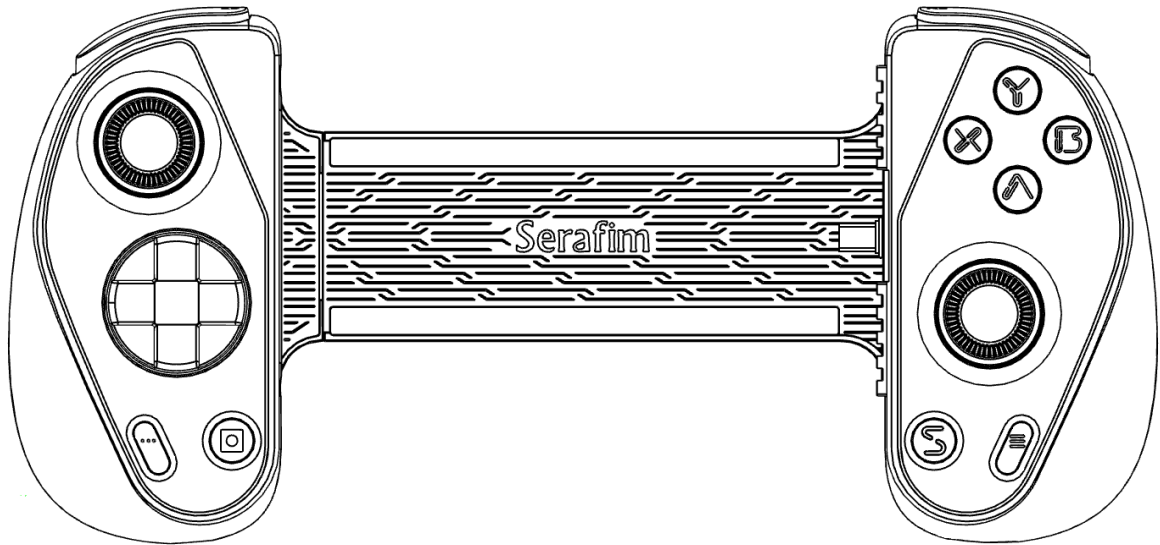

A. Serafim S3 Cloud Gaming Controller

Attach Serafim S3 to a phone

- 1 Align the top of your phone with the left side of the controller.
- 2 Stretch the controller until it fits your phone's length.

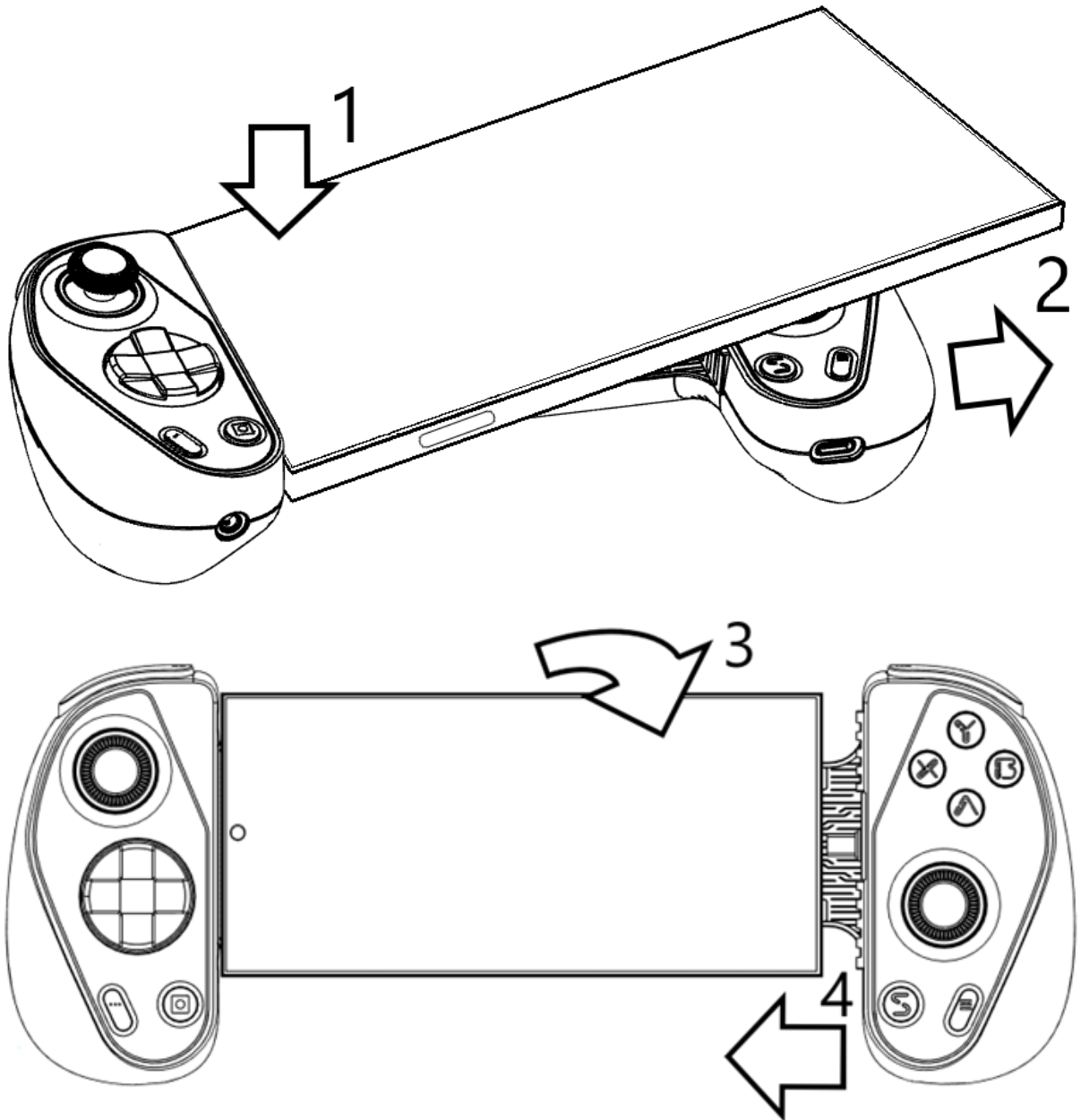

3. Place your phone in the controller.
4. Insert the controller's USB Type-C connector into the corresponding port on your phone.

Detach Serafim S3 from a phone

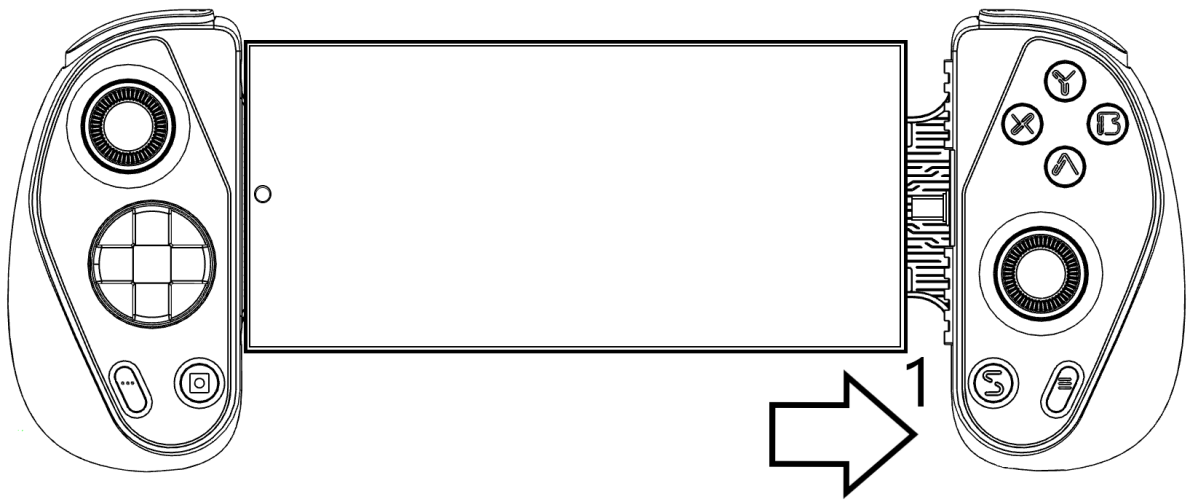

1. Pull the controller apart until the USB connector is completely out of the phone's USB port.
2. Lift the phone up to separate it from the controller.

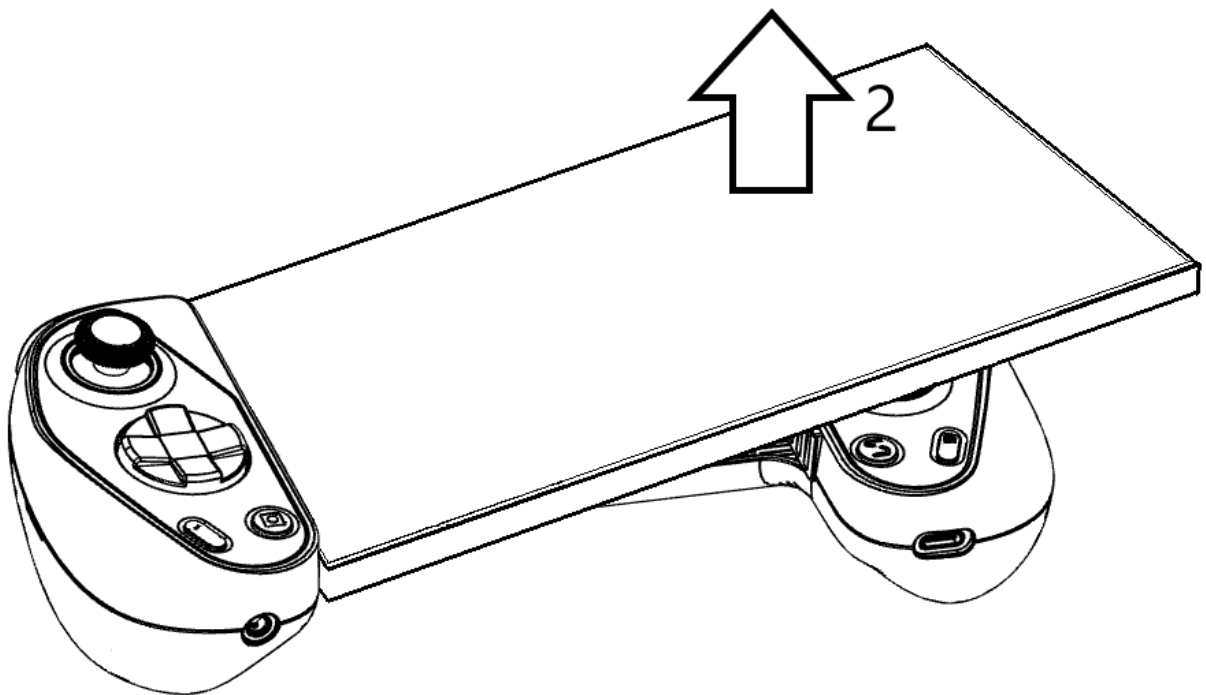

Controller buttons and ports

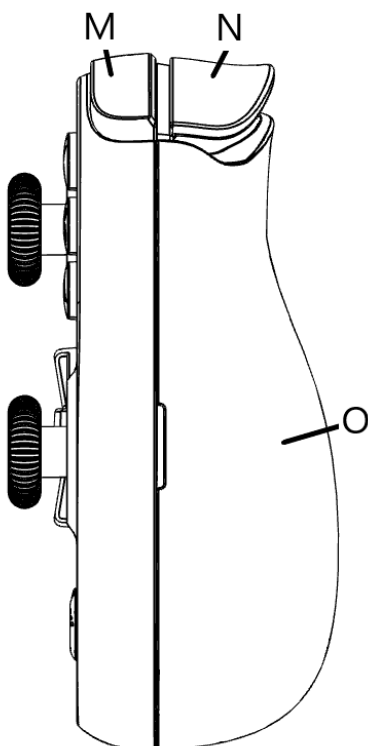
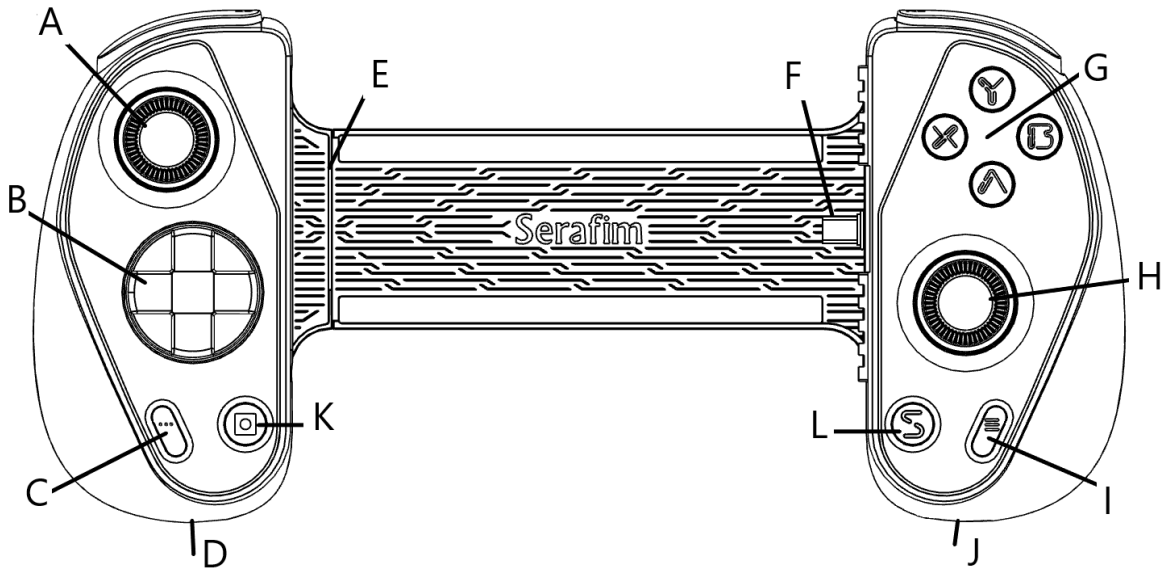

- A. Left Hall Effect Analog Joystick/L3 Button
- B. D-pad (Directional Pad)
- C. Select Button
- D. 3.5mm Earphone Jack
- E. Stretchable Bracket
- F. USB Type-C Connector
- G. A/B/X/Y Buttons
- H. Right Hall Effect Joystick/R3 Button
- I. Menu Button
- J. USB Type-C Port: Supports fast charging for your phone, allowing you to charge and play games at the same time
- K. Screenshot/Record Button: Short press to take a screenshot, long press to record
- L. Serafim Button
- M. R1/L1 Buttons
- N. R2/R2 Buttons: pressure-sensitive analog triggers
- O. Interchangeable Ergonomic Grips

Disclaimer

Copyright©

© Serafim Tech. Inc. All rights reserved.

No part of this manual, including the products and software described in it, may be reproduced, transmitted, transcribed, stored in a retrieval system, or any without the express written permission of Serafim Tech. Inc

For any further information please visit Serafim’s official website.:<https://www.serafim-tech.com>

- Product support page
<https://serafim-tech.com/support/>



If however, you encounter any problems we would be glad to answer all your concerns at sales@serafim-tech.com.

- Online Chat Support
<https://m.me/850793468343632>



Warranty

This product is covered by a one-year Serafim warranty. The following are not covered by the warranty:

1. Products that have been repaired, modified, or altered, unless such repair, modification, or alteration is authorized in writing by Serafim.
2. The warranty period begins on the date of purchase, as reflected on the invoice or receipt provided by the authorized reseller or distributor.

*** If there are any discrepancies between the descriptions and images in this manual and the actual product, the actual product shall prevail. Serafim Tech. Inc. reserves the right to interpret this warranty.**

Introduction of Serafim Console App

1 Serafim Console App Initial Setup

1.1 Login to the app with your Google account.



1.2 Follow the instructions in the app to enable the required permissions.

 **Recording Permission**
Please enable to use the live streaming feature.

 **Appear on Top**
Please enable to use the one-click return function.

 **USB Permission**
Please enable to use the screenshot function.

 **Notifications**
Allowing notifications to receive latest information. You can always disable notifications in the settings.





Recording Permission

Please enable to use the live streaming feature.



Appear on Top

Please enable to use the one-click return function.



USB Permission

Please enable to use the screenshot function.



Notifications

Allowing notifications to receive latest information. You can always disable notifications in the settings.



Recording Permission

Please enable to use the live streaming feature.



Appear on Top

Please enable to use the one-click return function.



USB Permission

Please enable to use the screenshot function.



Notifications

Allowing notifications to receive latest information. You can always disable notifications in the settings.

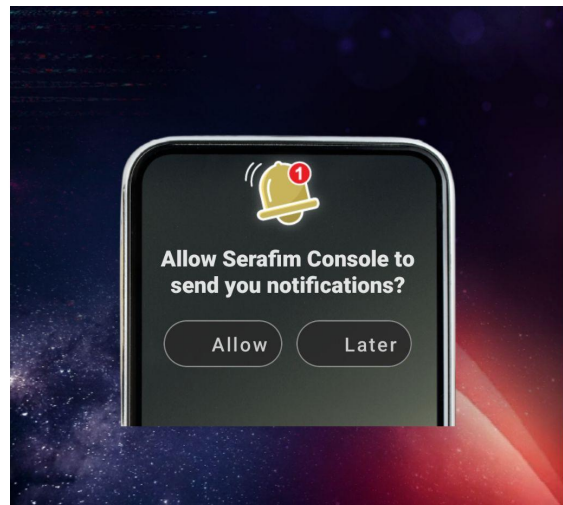

1.3 After the setup is complete, you will enter the main screen.



2 Navigation

2.1 Main Screen Overview

The left side icons from top to bottom are Home screen, Search, Twitch live streaming, video editing and sharing feature, Settings. The game list displayed at the top is a list of installed games, with the last played game displayed first.



Various game categories in the main screen

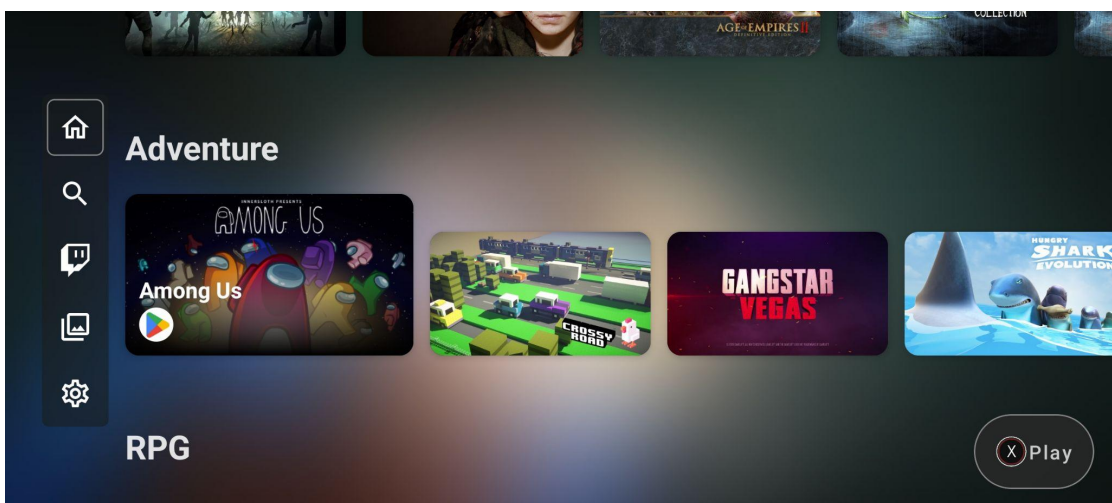
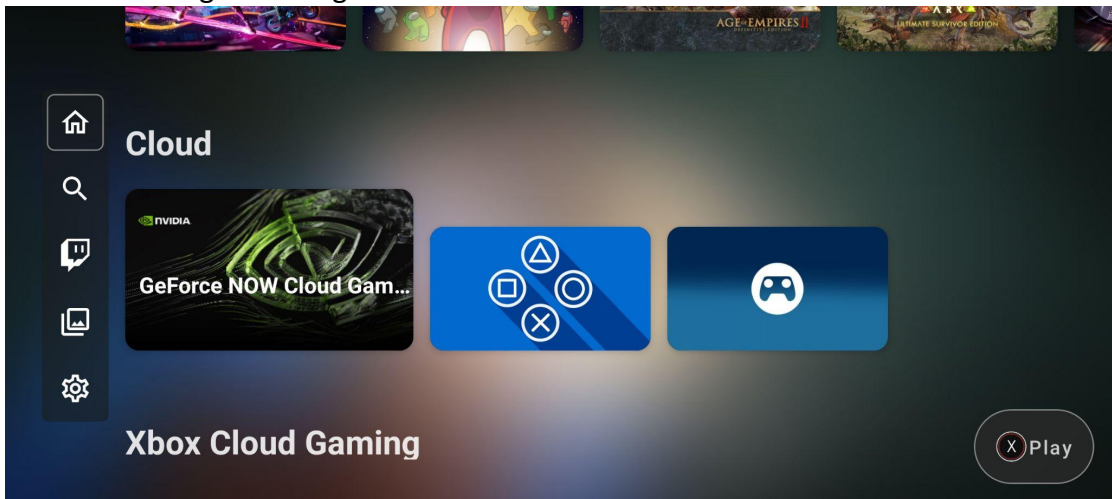

- 3 **Gameplay**
Select a game and press the X button to play it.



Or, press the A button to enter the game introduction screen, then press the X button to enter the game.

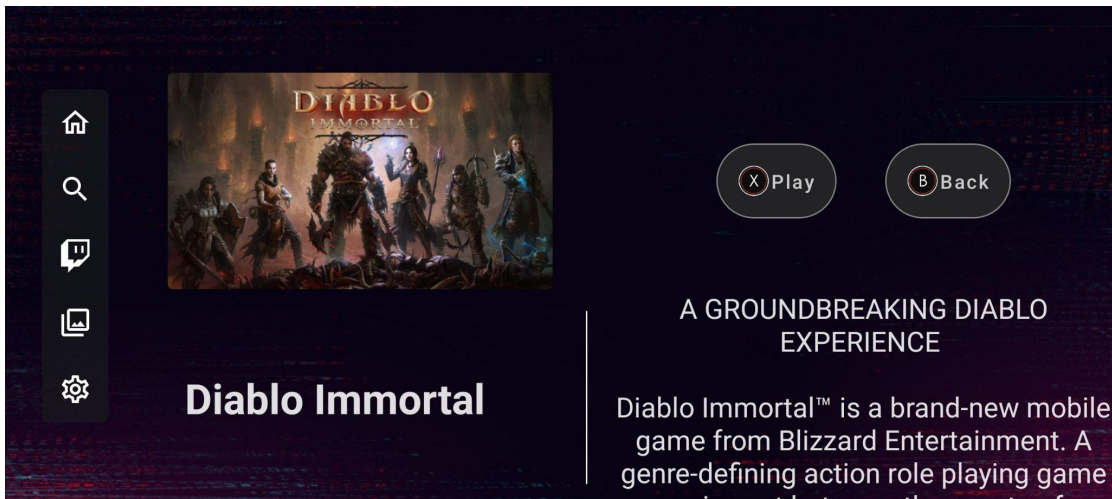

3.1 **Google Play**

To play a game from Google Play, simply select the game icon with the Google Play logo in the bottom left corner of the thumbnail and press the X button.

3.2 **Xbox Cloud Gaming**

* You will need an Xbox Game Pass Ultimate subscription to play Xbox Cloud Gaming. For a list of cloud gaming service regions, please visit the Xbox Game Pass website. To play a game from Xbox Cloud Gaming, simply select the game icon with the Xbox logo in the bottom left corner of the thumbnail and press the X button.

* The smoothness of cloud gaming depends on your current internet speed.

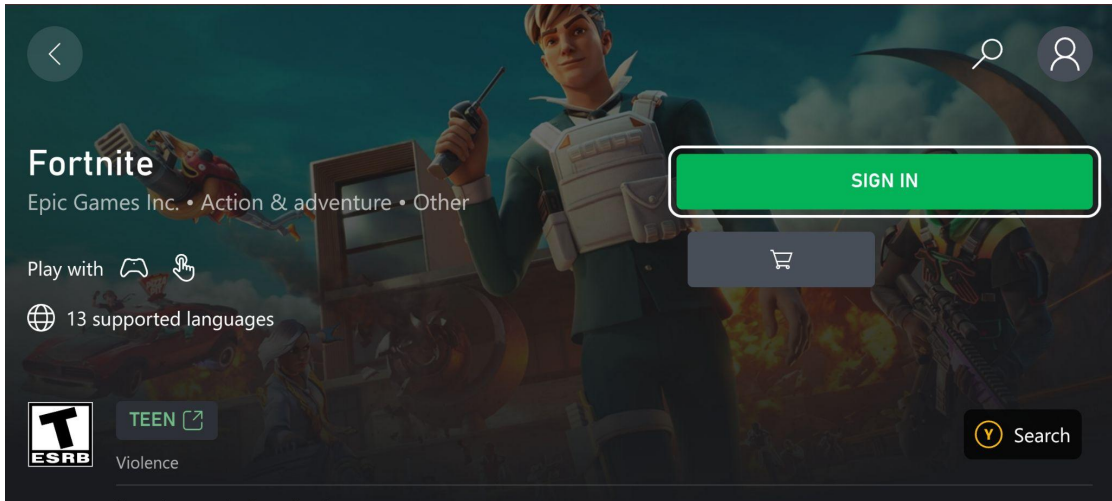

3.3 GeForce Now: Cloud gaming service

* You must have a GeForce Now subscription to play GeForce Now. To play GeForce Now, simply select the GeForce Now icon in the Cloud section of the main screen.

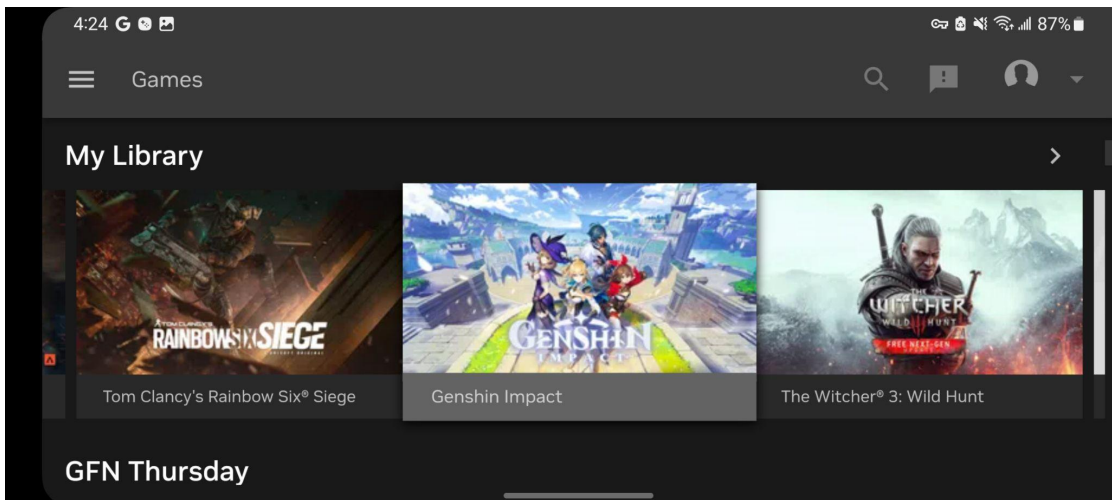

After logging in to your account, link your existing game accounts, such as Epic Games, Ubisoft, and Steam, in Settings.

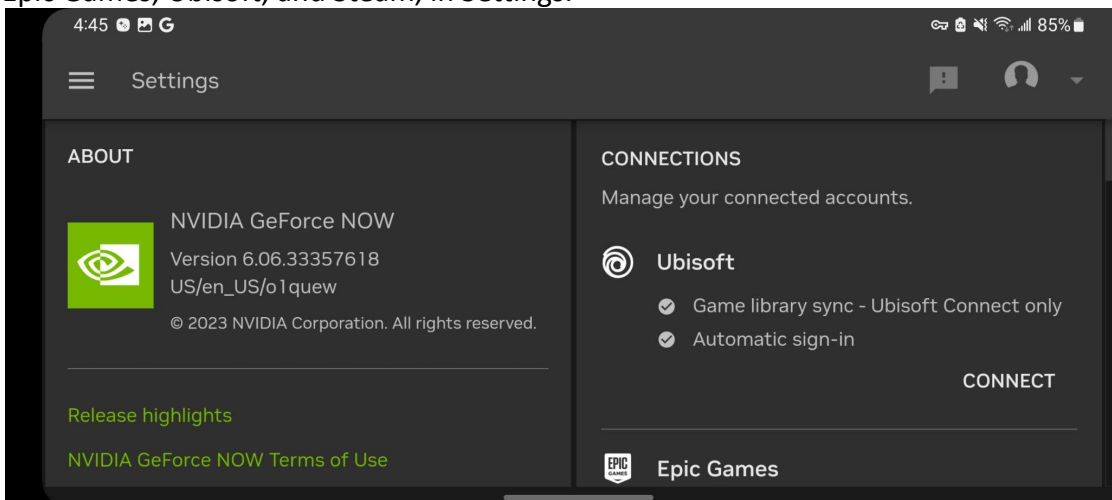

You can then start cloud gaming or play free games on GeForce Now.

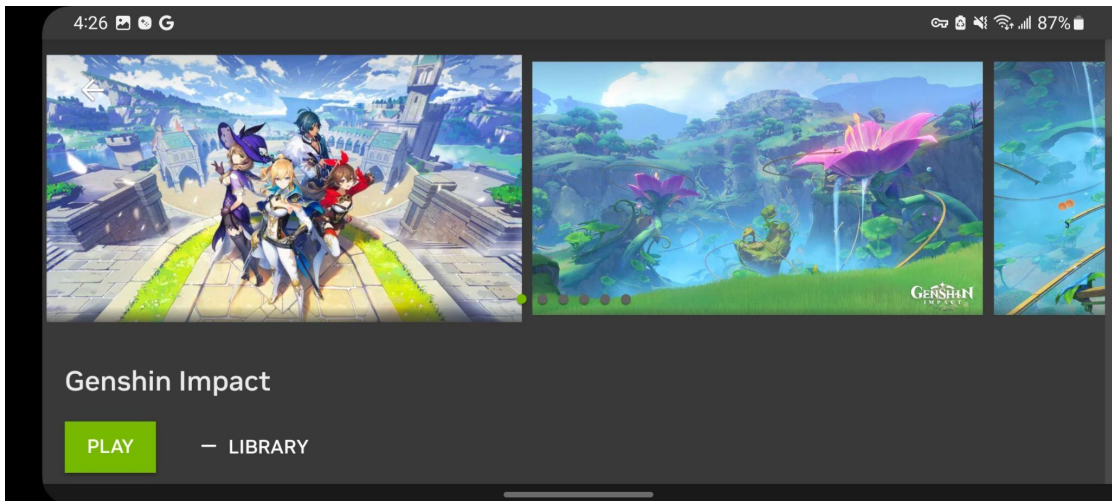

3.4 PlayStation 4/5: Remote Play

* You must have a PlayStation 4 or PlayStation 5 console and a PlayStation Network (PSN) account to play a PlayStation 4 or 5 remotely.

1. Download the PSPlay app from Google Play.
2. Select the PSPlay icon in the Cloud section of the main screen.
3. Log in to your PSN account.

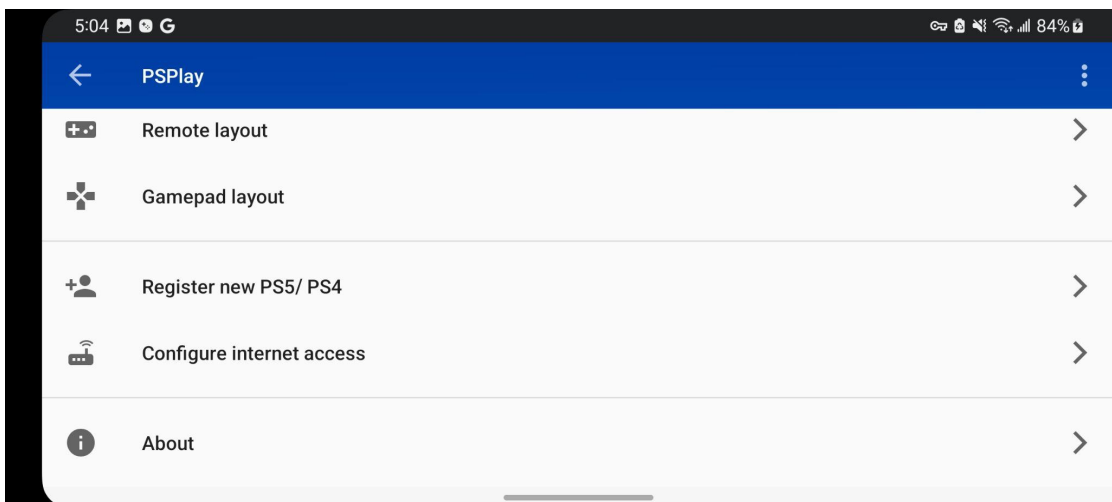

4. Press "Register new PS5/PS4" to bind your PlayStation 5 or 4.

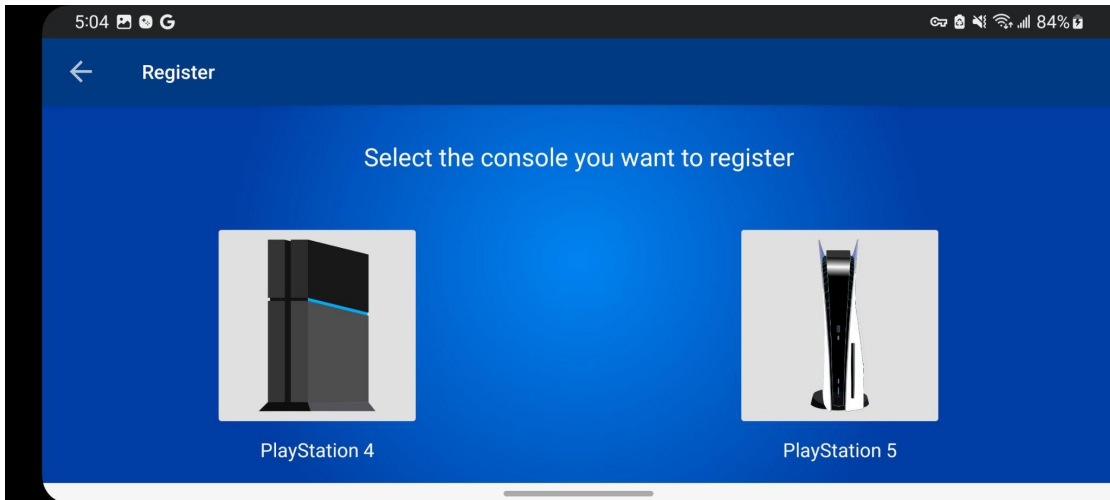

5. Select "Remote Connect" or "Local Connect" to play your game console remotely

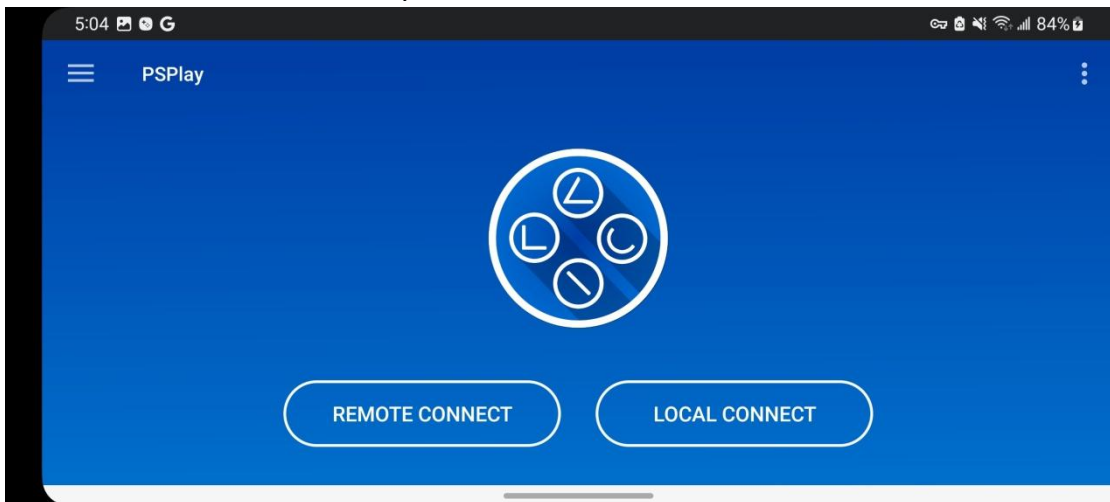

3.5 Steam Link: Cloud Gaming

* You must have a Steam account to use Steam Link.

1. Select the Steam Link icon in the Cloud section of the main screen.
2. Log in to your Steam account.
3. Follow the instructions in the app to set up.
4. Press "Start Playing" to start playing.

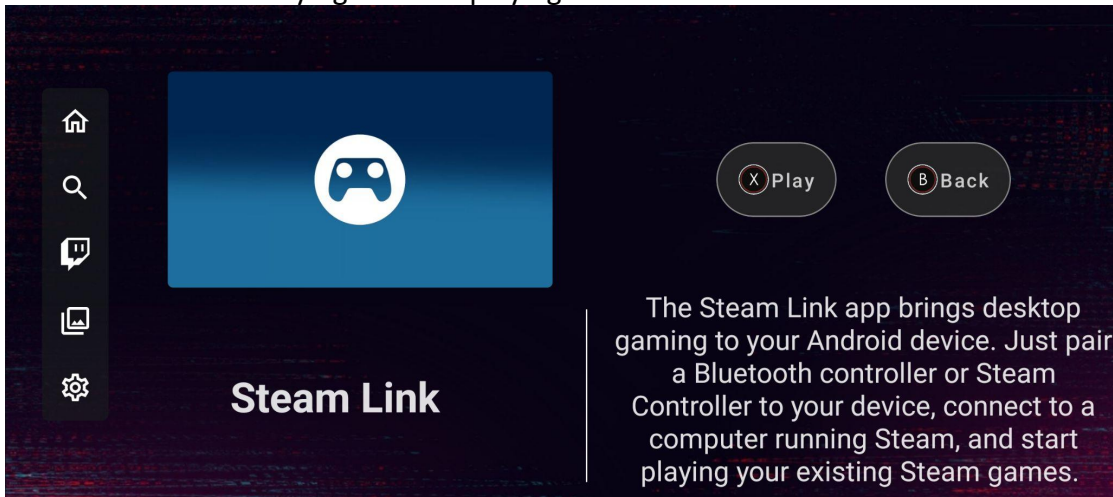

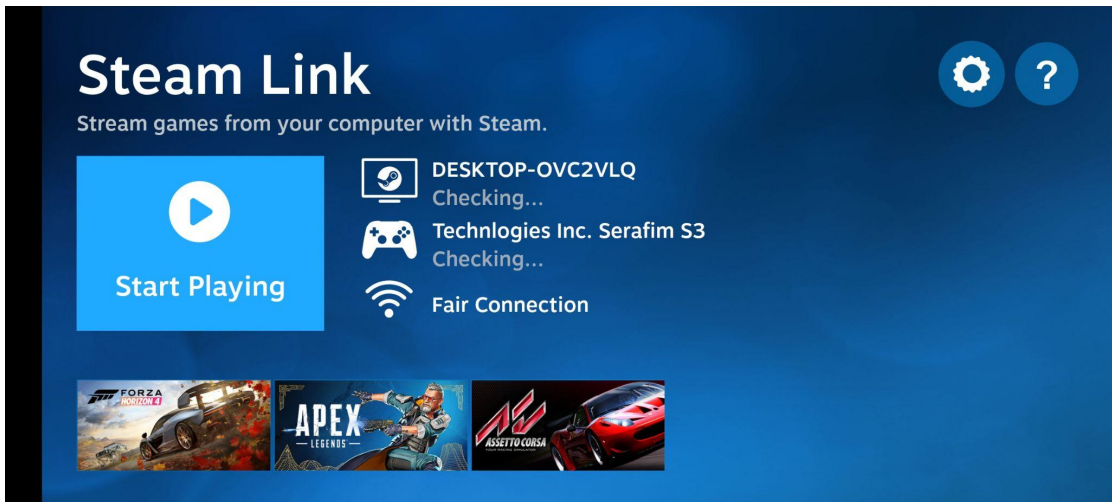

4 Screenshot/Recording and Editing/Sharing Features

4.1 Screenshot/Recording

To start recording, long-press the screenshot/recording button. A green dot will appear in the top right corner of the screen to indicate that you are recording, and a notification will appear on the phone screen.

* Simultaneous recording and streaming is not currently supported.

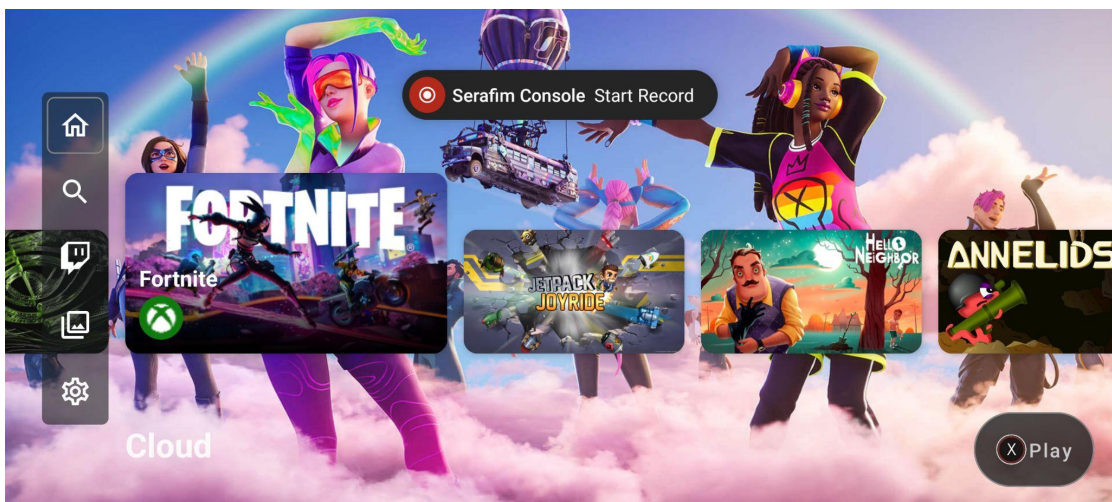

To stop recording, long-press the screenshot/recording button again.

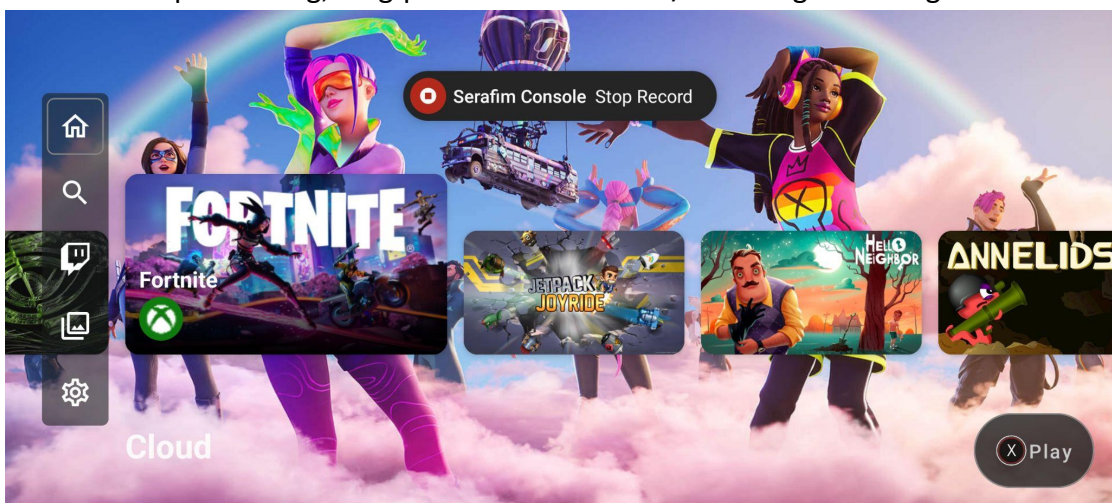

To take a screenshot, simply short-press the screenshot/recording button. Recorded files can be viewed on the video editing and sharing page.

4.2 Editing Recorded Videos

In the video editing and sharing page, select the video you want to edit.

* The latest recorded file is at the bottom of the page.

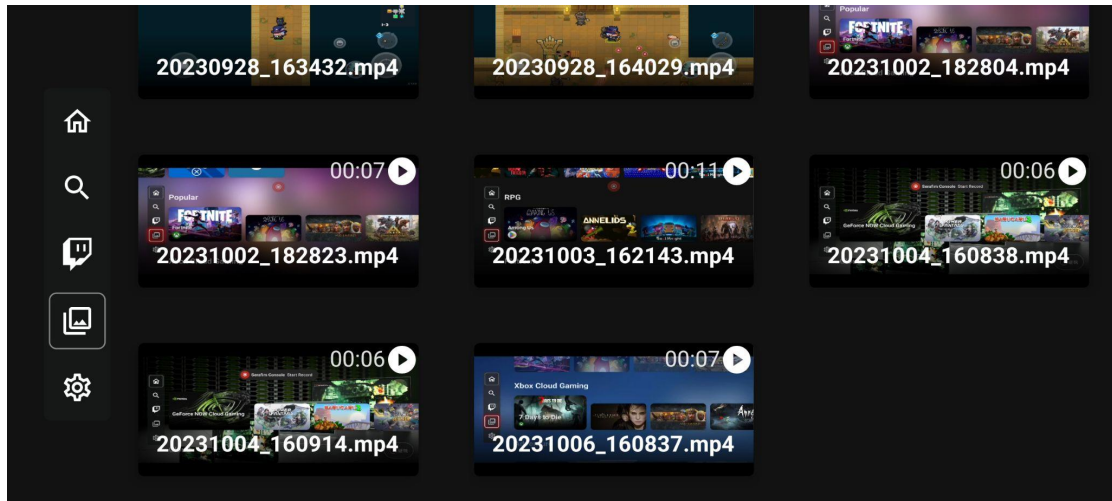

Press L3 (left joystick) and R3 (right joystick) to move the L3 and R3 in the video, and trim the video to the desired length. Press the A button to trim.

* The trimmed video will automatically be added to the bottom of the recorded file page.



4.3 Sharing Recorded Videos

In the video editing and sharing page, select the video you want to share. Press the Y button to share, and you can share it on various social platforms.

* The social platforms may vary depending on the phone manufacturer.

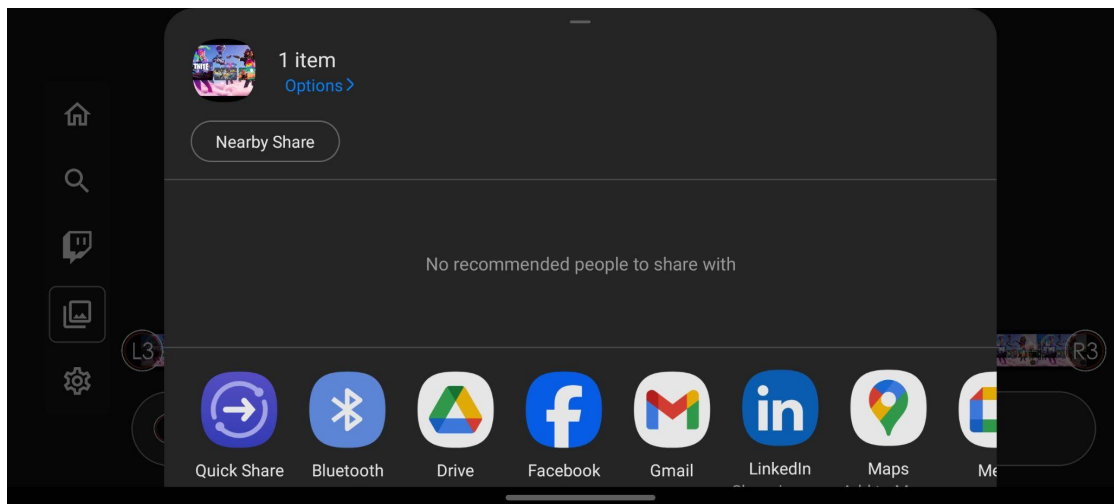

5 Twitch Streaming

To start Twitch streaming, select the Twitch icon on the main page. After logging into your account, you can start streaming gameplay on your phone.

- * A small green dot will appear in the top right corner of the screen to indicate that you are streaming. The green dot will disappear when you are no longer streaming.

- * Simultaneous recording and streaming is not currently supported.

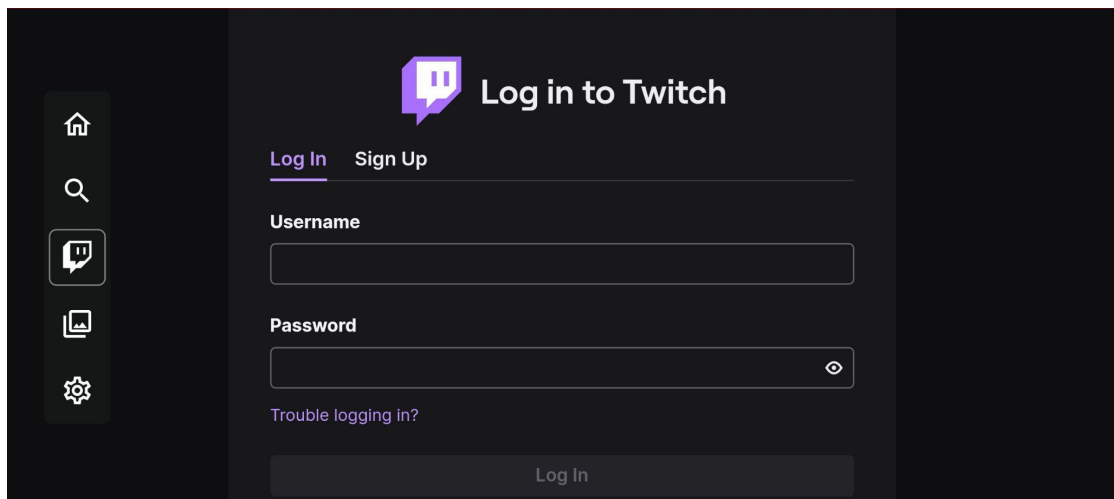

6 Miscellaneous settings

On the main page, select the Settings icon. The Account page allows you to log in or switch accounts.

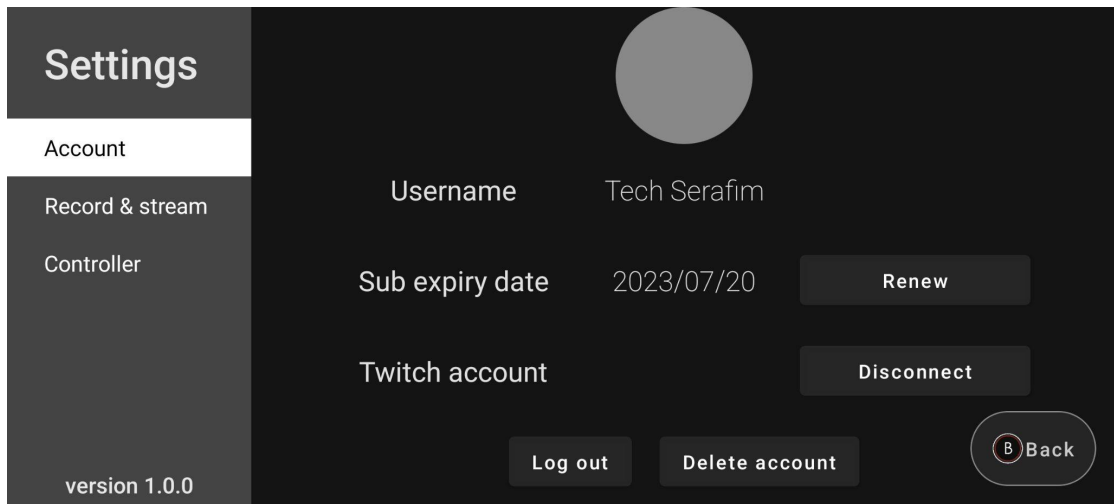

The Record & Stream page allows you to set the video quality and volume.

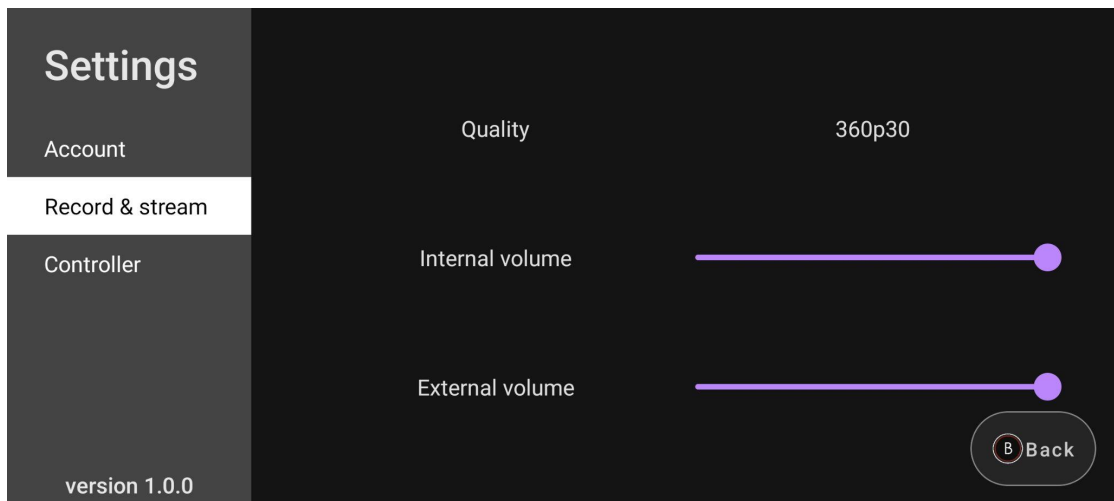

The Controller page provides features to test the functionality of buttons and update the firmware.

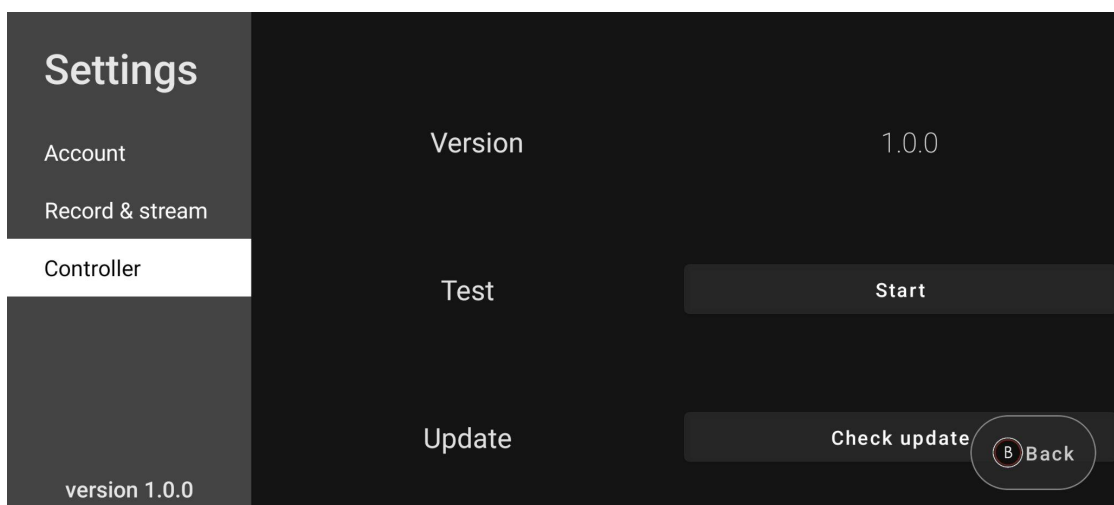

The Button Test page allows you to test the buttons and joysticks to make sure they are working properly. To exit the ButtonTest page, press and hold the Serafim button.

PC and Tablet Connection Instructions

Computer:

1. Connect a USB-C cable to a USB port on a computer that supports Windows 7 or higher.
2. The computer and tablet will automatically connect.

Tablet:

1. Connect a USB-C cable to the USB-C port on a tablet that supports Android 8.0 or higher.
2. The computer and tablet will automatically connect.

Technical Specifications

- Dimensions: 10.2 × 3.7 × 1.3 inches
- Weight: 5.1 ounces
- Extended Length: Fits phones with 17.9 cm or shorter in length
- Phone Case Thickness: Up to 3 mm
- Fast Charging: Supports Quick Charge
- Joysticks: Hall effect joysticks, joystick height: 8.22 mm, tilt angle: 21 degrees
- Triggers: 256-step Hall Effect linear triggers. Keystroke: 5.11 mm
- Audio Port: 3.5 mm headphone jack
- Compatibility: Android 8.0+ phones, USB Type-C connectors, OTG
- Connectors: USB Type-C port, USB Type-C socket

Frequently asked questions

Q1. Are the L2 and R2 triggers pressure-sensitive?

A1: Yes, the L2 and R2 triggers are pressure-sensitive hall effect triggers.

Q2. What is the approximate latency when connecting the controller?

A2: The controller uses a wired connection to the phone, with a latency of less than 3 milliseconds.

Q3. Can I connect it to my computer to play games?

A3: Yes, you can connect it to a Windows computer to play games.

Q4. Does it support emulators like PPSSPP?

A4: Yes, it does.

Q5. What thickness of phone case can I use?

A5: We recommend using a phone case with a thickness of 3mm or less.

Q6. What systems does the controller app support?

A6: The dedicated Serafim Console app currently supports Android 8.0 and above. Smartphones come with a USB Type-C port and OTG (On-The-Go) support. Please note that if your phone is not listed below, it doesn't necessarily mean that it is not compatible with the Serafim S3 Gamepad. It simply means that we are still working hard to confirm its compatibility. As we confirm compatibility with more models, we will continue to update this list.

Google Pixel 7 Series,6 Series,5 Series,4,4XL,3,3XL,2, 2XL

LG G7 ThinQ

Samsung Galaxy S8, S8+, S10, S10+, S20, S21, S22, S23

Samsung Galaxy Note9,8, Note10, Note10+, Note20 Ultra 5G

Samsung Galaxy Z Flip4, Flip3, Flip

Samsung Galaxy A33, A53

Honor 50

Series Nothing 1

Series Oppo Find X5 Pro

Series OnePlus 9 Pro

Series P30 PO

Realme 7 Pro

vivo Pro+

Xiaomi POCO X3 Pro

Safety Notes

If you encounter any problems operating the device and troubleshooting does not help, please unplug the device and contact our online customer service or visit <https://serafim-tech.com/contact/> for assistance. Do not attempt to disassemble or repair this device under any circumstances, as doing so will void the warranty.

Keep the device away from liquids or any humid environment. Operate this device within the ideal temperature range (0°C (32°F) to 45°C (113°F)). If the temperature exceeds the ideal range, turn off the device until the temperature returns to the ideal range.

Product Registration

Please register from our website, the warranty period is 12 months from the date of arrival.

- Register now
<https://serafim-tech.com/register/>



Product name		Product SN	
Purchase date		Customer name	
Store name		Purchase amount	

Compliance Information

Federal Communications Commission Declaration of Conformity

This device complies with part 15 of the FCC Rules. Operation is subject to the following two conditions: (1) This device may not cause harmful interference, and (2) this device must accept any interference received, including interference that may cause undesired operation.

FCC Statement

This device complies with Part 15 of FCC Rules. Operation is subject to the following two conditions: (1) This device may not cause harmful interference, and (2) this device must accept any interference received, including interference that may cause undesired operation.

FCC Caution

Changes or modifications not expressly approved by the party responsible for compliance could void the users's authority to operate the equipment.

Note

This equipment has been tested and found to comply with the limits for a Class B digital device, pursuant to part 15 of the FCC Rules. These limits are designed to provide reasonable protection against harmful interference in a residential installation. This equipment generates, uses and can radiate radio frequency energy and, if not installed and used in accordance with the instructions, may cause harmful interference to radio communications. However, there is no guarantee that interference will not occur in a particular installation. If this equipment does cause harmful interference to radio or television reception, which can be determined by turning the equipment off and on, the user is encouraged to try to correct the interference by one or more of the following measures:

- Reorient or relocate the receiving antenna.
- Increase the separation between the equipment and receiver.
- Connect the equipment into an outlet on a circuit different from that to which the receiver is connected.
- Consult the dealer or an experienced radio/TV technician for help.

RoHS
compliant



外箱

